

Showline

SL eSTROBE 130

PHILIPS

The SL eSTROBE 130 luminaire utilizes 576 cool white LEDs to deliver an exceptional output of 28000 lumens. Separate control of four zones allows unique design flexibility.

Constructed from robust diecast aluminium and consuming only 150W, the SL eSTROBE 130 is an ideal replacement for high current Xenon strobe luminaires. With a beam angle of 120 degrees, and up to two minutes of user selectable "on" duration, the SL eSTROBE 130 offers designers a flexible solution for short throw illumination effects.

A split yoke bracket permits quick setup in any orientation, and configuration is made easy through use of the simple, LCD menu system. The SL eSTROBE 130 is RDM enabled, allowing for fast commissioning and testing from a remote location.

Whether in use of stages, buildings, clubs, landscapes or other entertainment venues, the SL eStrobe 130 provides designers with a flexible effect luminaire with superior optical quality and uniformity.



Features :

- Rugged Construction
- 6500K White LED's for an exceptional output of 28000 lumens
- 8 or 16-bit DMX-512A operation for smooth stepless fades
- On-board LCD Menu System for addressing and setup
- Remote configuration available via RDM
- 5-pin DMX-512A(RDM) in and through connections

Drawing Diagram :

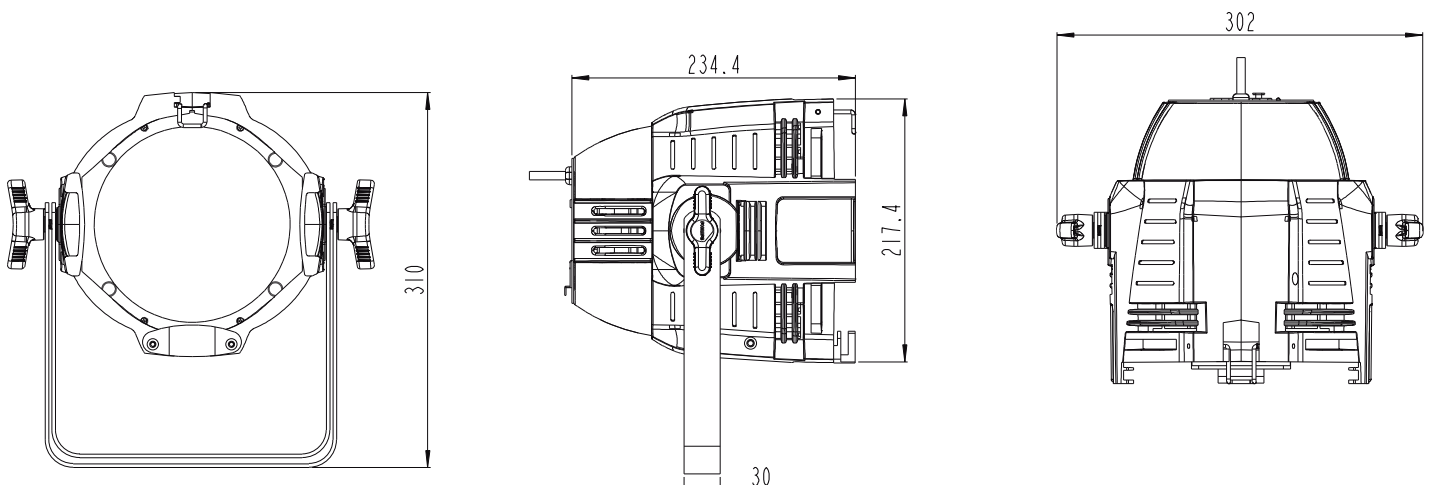

Technical Specifications :

Version:

SL eSTROBE I30, IP20

Optics:

120 degree beam angle
576 of 6500K LEDs

Controls:

DMX-512A(RDM)
Local LCD control
Master / Slave

Modes:

1 Channel
3 Channels
4 Channels
16 bit Control
Zone Mapping

Features:

Chase - Strobe + Duration Effect Engine
LED & Tungsten Curves selection
4 of dimming curves

Physical:

90 - 240VAC, 150W
235mm x 218mm x 302mm, 5.5Kg
CE and C-Tick, IP20

Luminance:

28000 lumens
CRI/CQS:
90



Ordering Information :

SLeSTROBEI30

SL eSTROBE I30, IP20

Philips Group 2013. All rights reserved.

The Company reserves the right to make any variation in design or construction to the equipment described. E&OE. Philips Entertainment delivers fully integrated lighting solutions; from simple lamps to complete systems designed with the specific needs of the entertainment and specialized display lighting markets.

Philips Entertainment U.S.
10911 Petal Street
Dallas, TX 75238
Tel: +1 214647 7880
Fax: +1 214647 8030

Philips Entertainment Lighting Asia Limited
Unit C, 14/F, Roxy Industry Centre
No. 41 - 49 Kwai Cheong Road
Kwai Chung, N.T. Hong Kong
Tel: +852 27969786
Fax: +852 27986546

Philips Entertainment Group Europe
Rondweg Zuid 85
Winterswijk 7102 JD Netherlands
Tel: +31 543-542343
Fax: +31 53 4500425

Philips Entertainment New Zealand
19 - 21 Kawana Street, Northcote
Auckland 0627, New Zealand
Tel: +64 9481 0100
Fax: +64 9481 0101