

Showline

SL BEAM 100

PHILIPS



The SL BEAM 100 LED Luminaire delivers a bright homogenous beam with three independent zones of control. The luminaire's 7 RGBW 15-watt LEDs deliver over 1500 lumens of output and a crisp edged beam. The useful zoom range of 5° to 45° provides designers with the freedom to use the SL BEAM 100 as a narrow beamlight special with defined edges, or as a wash luminaire with a flat, even field.

Choose the appropriate DMX mode to meet your control requirements. Utilize the built in color and effect presets for speed and simplicity, or take direct control of the three LED zones and create your own unique designs on the front of the luminaire.

As with every Showline luminaire, the SL BEAM 100 utilizes the Harmonize Color Calibration system. This revolutionary process ensures color matching not only between luminaires, but also between individual pixels of each and every luminaire. Seamless color changes, powerful output, a useful zoom range and creative programming possibilities enable the SL BEAM 100 to fit into a wide range of lighting applications.

Features :

- Rugged Construction
- Philips Lumileds RGBW LED's for exceptional output and color
- Up to 3 zones of individual LED control
- Built-in color presets, effects and chases
- HSIC (Hue - Saturation - Intensity - Color temperature) operation mode
- 8 or 16-bit DMX-512A operation for smooth stepless fades
- On-board LCD Menu System for addressing and setup
- Remote configuration available via RDM
- PowerCon in and thru power connections
- 5-pin DMX-512A(RDM) in and thru connections

Dimensions :

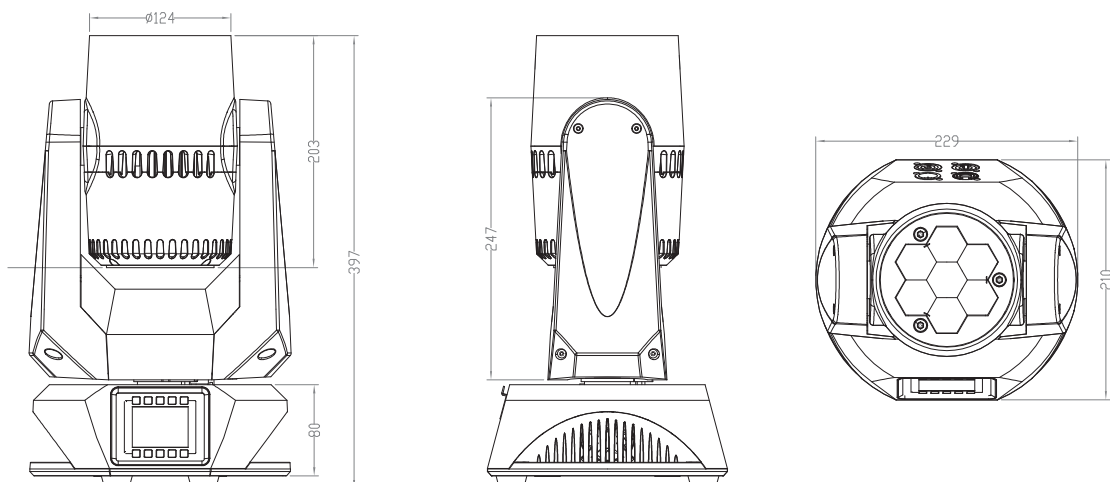

Technical Specifications :

Version:
SL BEAM 100 RGBW, IP20

Optics:
5 - 45 degree zoom
7 high power LEDs
CCT 2700K - 10,000K(user adjustable)

Controls:
DMX-512A(RDM)
Local LCD control
Master/slave

Features:
Color Gel filter preset
Chase - Strobe + Duration Effect Engine
Up to 3 zones of individual control Zone effects
LED & Tungsten Curves selection
Pan/Tilt shape Effect Engine

Modes:
HSIC
8 bit RGBW
16 bit RGBW

Physical:
100-240VAC, 150W
397mm x 229mm x 210mm (15.6" x 9" x 8.3")
7.6kg (16.72 lbs)
CE

Luminance:
> 1500 lumens (RGBW)
CRI/CQS:
>90 (RGBW)

Ordering Information :

SLBEAM100

SL BEAM 100 Moving LED RGBW, IP20

Harmonize Color Calibration Technology

At the heart of all Showline products is Philips Harmonize Calibration technology. Harmonize is a proprietary, advanced LED color matching system, consisting of 3 correction modules: RGB, RGBW and Cool White/Warm White. Every Showline fixture undergoes rigorous testing to provide you with consistent control of color and intensity as well as output of the highest quality.

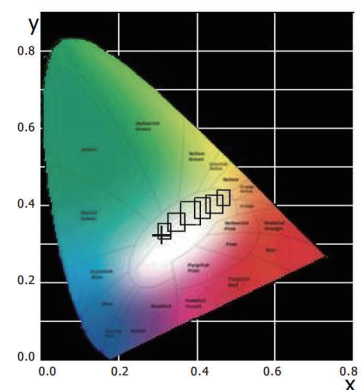

Philips Group 2014. All rights reserved.

The Company reserves the right to make any variation in design or construction to the equipment described. E&OE. Philips Entertainment delivers fully integrated lighting solutions; from simple lamps to complete systems designed with the specific needs of the entertainment and specialized display lighting markets.

Philips Entertainment U.S.
10911 Petal Street
Dallas, TX 75238
Tel: +1 214647 7880
Fax: +1 214647 8030

Philips Entertainment Lighting Asia Limited
Unit C, 14/F, Roxy Industry Centre
No. 41 - 49 Kwai Cheong Road
Kwai Chung, N.T. Hong Kong
Tel: +852 27969786
Fax: +852 27986546

Philips Entertainment Group Europe
Rondweg Zuid 85
Winterswijk 7102 JD Netherlands
Tel: +31 543-542343
Fax: +31 53 4500425

Philips Entertainment New Zealand
19 - 21 Kawana Street, Northcote
Auckland 0627, New Zealand
Tel: +64 9481 0100
Fax: +64 9481 0101