

FX16ii



EFX



EPM



MFX



MPM



FX16ii

EFX

EPM

MFX

MPM

MULTI PURPOSE MIXERS





FX16ii

THE PROFESSIONAL'S CHOICE FOR MORE THAN 10 YEARS, NOW THE FX16 GETS STUNNING 24-BIT LEXICON EFFECTS.

Great sound quality, professional build quality, flexible 4-bus architecture and a space-saving sixteen mic inputs and direct outputs in a rack-mounting frame made the original Soundcraft FX16 popular in both live and recording applications. Now the pro's choice gets even better with a new 24-bit Lexicon on-board effects section and universal internal power supply (see right).

A comprehensive feature set includes 16 mic/line inputs and 26 inputs to mix in total (including stereo returns and tape return to mix). In addition to the mix outputs, 2 buses allow groups of instruments to be sent to additional speakers, or sub-grouped to mix. 16 Direct Outputs are individually fader pre-post

switchable making them equally useful for multitrack recording or live use and both Solo In Place and PFL solo are available, for studio monitoring and channel gain set-up applications respectively.

All 16 mic/line inputs are equipped with high quality UltraMic™ preamps while a 'truly British' 3-band EQ with swept mid benefits from custom designed pots which give greater control across carefully chosen frequencies. There are 4 Auxiliary Sends, including a dedicated effects send, 1 pre-fade send and 2 pre/post-fader selectable sends which are equally useful as extra foldback sends or as effects sends in studio mixdown situations. In addition, there are 4 Stereo returns, a separate Mono Sum Output and 2 Subgroup Outputs.

A truly professional feature set is completed by 100mm faders for precision mixing control, and the FX16ii fits all of these features into a rugged, compact frame which can be optionally rack-mounted into a 10U space. Cables can be conveniently located behind the rack by simply rotating the connector pod.

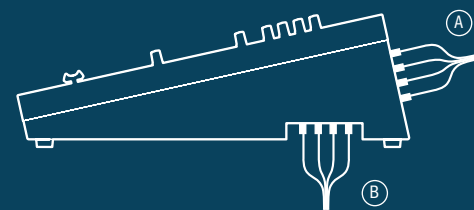

A - Connector pod positioned for desktop use.
B - Connector pod rotated for rack-mounting.

KEY FEATURES

- 26 inputs as standard
- 16 mono channels with UltraMic™ preamps
- 4 stereo returns
- 4-bus architecture with sub-group routable to mix
- 24-bit Lexicon effects processor
- Direct outputs for multitrack recording individually switchable for pre/post fade operation
- 100mm faders
- Inserts on all mono channels
- Inserts on stereo mix bus
- 3-band 'British' EQ with swept mid-band
- 100Hz high-pass filter
- +48V phantom power
- 10 segment tri-coloured metering
- 2 sub-group outputs
- Rack mountable with rotating rear panel
- Universal internal power supply

ON-BOARD EFFECTS FROM THE WORLD-LEADERS IN DIGITAL SIGNAL PROCESSING.

lexicon [®] 24-BIT DIGITAL EFFECTS PROCESSOR	
A:PRE-DEL B:TME/SPD	BANK A BANK B
1	S.HALL S.DLY
2	L.HALL D.DLY
3	V.HALL T.DLY
4	D.HALL P.DLY
5	S.PLT M.DLY
6	L.PLT R.DLY
7	V.PLT CHORUS
8	D.PLT FLANGR
9	ROOM PHASR
10	STUDIO TREM/P
11	CHMBR ROTRY
12	AMB VIBRTO
13	ARENA RV/DL S
14	GATED RV/DL L
15	REV PHSDEL
16	SPRING ROTDEL

A:DECAY
B:FBK/DPTH

A:VARI
B:

FX TO AUX1

CLIP

A FX ON B

PROGRAM SELECT

PFL MUTE

STORE TAP TEMPO

For more than 35 years, Lexicon has been synonymous with the best reverb and processing in the business, continuously introducing ground-breaking technology to the audio industry. Today, Lexicon processing is heard on over 80% of all recordings - broadcast and film soundtracks. Now Soundcraft empowers three ranges of multi-purpose mixers - FX16ii, EFX, and MFX - with stunning 24-bit digital effects processing using the same AudioDNA® processor used in the highly-acclaimed Lexicon MX500 processor.

A total of 32 preset effects including reverbs, delays and choruses are available along with 3 effects parameter controls and a tap tempo button.

The versatility of the effects section is further enhanced by the facility to store user-defined effects settings allowing the user to return to their favourite settings time after time.

Effects can be switched on and off using a footswitch.

Effects section from EFX mixer shown above. Features and functionality of FX16ii, EFX and MFX mixers are the same - layout differs slightly.



EPM/EFX

SOUNDCRAFT SOUND QUALITY, PERFORMANCE AND VALUE FOR MONEY IN A VERSATILE RANGE OF MULTI PURPOSE MIXERS – AVAILABLE WITH AND WITHOUT EFFECTS.

EFX/EPM mixers bring Soundcraft sound quality, performance and value-for-money to a wide range of applications including recording, live sound, install and broadcast.

Available in 8 and 12 mono input channel configurations, the EFX mixers feature built-in Lexicon 24-bit processing, providing access to 32 world class reverb, delay and chorus effects (see previous page). For users preferring to use external processing, three EPM mixers – (6, 8 and 12 mono inputs – replace the EFX’s internal FX send with a

second Aux send. All EFX/EPM mixers feature 2 stereo channels as standard.

Configured for desktop use with all audio connectors conveniently located on the top panel, EFX/EPM mixers can be easily converted for rack-mounting using an optional rack kit, with each mixer occupying just 8U of standard rack space.

EFX/EPM mixers feature professional +48V phantom power for condenser microphones and use the same GB30 microphone

preamps used on Soundcraft’s acclaimed, large format GB Series consoles to achieve exceptional clarity, low-noise and controlled overload characteristics.

Drawing on more than 30 years of experience manufacturing professional mixing consoles, Soundcraft has equipped the EFX/EPMs with all the appropriate features for modern mixing applications, at the same time creating an uncluttered and intuitive control surface that enhances the operator experience.

Visual feedback is further enhanced by peak LEDs on all input channels which are fed from multiple points in the signal path to ensure that nothing is overlooked. The LEDs illuminate in proportion to the signal level when approaching peaks, enabling the quality of the signal to be maximised through using all the available headroom.

Furthermore, the main stereo mix has 10-segment LED meters with a PFL Active LED to indicate that channels are being solo’d.

KEY FEATURES	EPM	EFX
• Built-in Lexicon 24-bit effects		✓
• Multi-point signal channel status monitoring with proportional illumination	✓	✓
• Precision GB30 mic pre-amps	✓	✓
• True, professional +48V phantom power for condenser microphones	✓	✓
• Insert points for external processing	✓	✓
• Choice of frame sizes, each with 2 stereo inputs	6/8/12	8/12
• Aux sends globally switchable pre or post-fade	2	1
• FX send	None	1
• Universal internal power supply	✓	✓
• Simple rack mounting options	✓	✓



MORE CHANNELS, MORE AUXES AND 2 GROUP BUSES.
WHEN YOU NEED EVEN GREATER FLEXIBILITY,
YOU NEED MFX/MPM.

MFX

MPM



MPM/MFX

Also suitable for music production, Soundcraft's MFX/MPM mixers are compact and ideally equipped for live sound applications including fixed installations, houses of worship and portable PA.

8, 12 and 20 mono input MFX mixers are empowered by built-in 24-bit Lexicon processing, delivering 32 stunning reverb, delay and chorus effects (see opening page). Both 12 and 20 mono input MPM mixers replace the MFX's internal FX send with a third Aux send, for operators preferring to use external effects. All MFX/MPM mixers include 2

stereo input channels along with a 2-track record output and a 2-track replay input which allows interval music to be easily played from CD, MP3 or other music source.

For increased versatility, each model in the MFX/MPM range has two subgroups as well as a main stereo mix, making control of groups of channels much easier to manage. These are supplemented by 2 (MFX) or 3 (MPM) Auxiliary busses which can be used for effects sends or to provide a foldback monitor mix for artists.

Sound quality is assured by Soundcraft's now-legendary GB30 mic preamp and the use of professional condenser microphones is facilitated by the provision of globally switched +48V phantom power. An integral universal power supply negates the need for an external power module.

KEY FEATURES	MPM	MFX
• Built-in Lexicon 24-bit effects		✓
• Precision GB30 mic pre-amps	✓	✓
• True, professional +48V phantom power for condenser microphones	✓	✓
• 2 Group busses	✓	✓
• Stereo Mix output	✓	✓
• Choice of frame sizes, each with 2 stereo inputs	12/20	8/12/20
• Aux sends, globally switchable pre or post-fade	2 + 1 post fade	2
• FX send	None	1
• Universal internal power supply	✓	✓
• Optional rack ears available	✓	✓



FX16ii
Mono Input Channel

FX16ii
Master Section

MONO INPUT MODULE

Mic Input

A female XLR connector accepts balanced or unbalanced mic signals. At -127dbu the mic amp is extremely quiet and transparent with excellent overload characteristics.

Line Input

A balanced 1/4" jack for connecting balanced or unbalanced electronic instruments, such as keyboards.

Insert

A pre-EQ insert is available on a 1/4" jack.

Direct Output

A Direct Output for multitrack recording is available on a 1/4" jack can be switched pre/post fader.

Sensitivity

A rotary control on each input alters the sensitivity of the input signal, from -60dBu to 0dB.

High Pass Filter

A switchable stereo 18dB/octave 100Hz high-pass filter can be used to cut stage rumble.

EQ Section

Equalisation is split into three bands with shelving HF and LF controls providing 15dB of cut or boost (gain adjustment) at 12kHz and 80Hz. A swept mid frequency control enables frequencies from 150Hz to 3.5kHz to be adjusted with up to 15dB of cut or boost at the selected frequency, with a Q of 1.5.

Auxiliary Section

For sending separate monitor mixes in live applications, or for use with fx units three aux sends on each input channel cater for all requirements. Aux 1 is permanently sourced pre-fade, Aux 2 is individually switchable pre/post fade and Aux 3 is permanently sourced post fade.

FX Send

For sending signal to the internal 24-bit Lexicon effects.

Pan, Muting, Sub, Mix and Solo

The Pan control positions each channel's signal across the stereo image, with a Mute button to cut the signal completely. The Sub/Mix buttons sends the signal to a separate group (for multitrack recording or to an additional set of speakers) or to a subgroup to mix. Both Solo In Place and PFL solo are available, for studio monitoring and channel gain set-up applications respectively.

Faders and Metering

Each mono channel features a smooth 100mm fader, and a peak level LED indicating signal levels within 6dB of clipping.

MASTER SECTION

Effects

A rotary control selects the effect program, with three rotary controls for effect parameters and one to control the effects level sent to Aux 1. Buttons for PFL, Mute, Store (user effect set-up) and Tap Tempo (for time/speed-based effects such as delays). Footswitch input for FX on/off.

+48V Phantom Power

Dual global control over professional +48V phantom power is offered via push buttons (split channels 1-8 and 9-16). LEDs illuminate when active.

2-Track Inputs

2-track recorder inputs are on unbalanced RCA phono connectors. A 2-track level control is also provided.

Monitor Output and Mix Insert

Available on balanced 1/4" jacks.

Sub Group Output and Insert

Available on balanced 1/4" jacks.

Mix Outputs

The main left and right mix outputs are provided on balanced XLR connectors.

Monitor & Phones Level

Levels sent to the monitor output and headphones can be independently adjusted using these two rotary controls. And when a pair of headphones are plugged into the phones socket at the bottom right of the mixer, the monitor outputs are still operational for simultaneous listening by a performer and engineer.

Faders and Metering

Controlling the sub group outputs and overall stereo mix level are two pairs of 100mm faders, with a Sub to Mix switch provided. Two 10-segment 3-colour LED peak-reading bargraph meters display the L-R output levels, which are replaced by an active Solo signal. A Solo Mode switch selects PFL/AFL Solo or SIP Solo, with indicated by LEDs. 2-track, Mix and Sub selector switches are also provided.

Aux Outputs and Stereo Returns

3 aux outputs are available on 1/4" jack, each with rotary level controls and AFL switch. In addition, a rotary level control and AFL switch is provided for FX. 4 pairs of stereo returns are provided on 1/4" jacks. Returns 1-3 have their own level control switchable to Aux 1 or 2 with a separate level control switchable to Mix or Sub. Return 4 has its own level control switchable to Aux 3 or FX send with a separate level control switchable to Mix or Sub. The FX return has its own level control switchable to Aux 1 or 2 with a separate level control switchable to Mix or Sub.

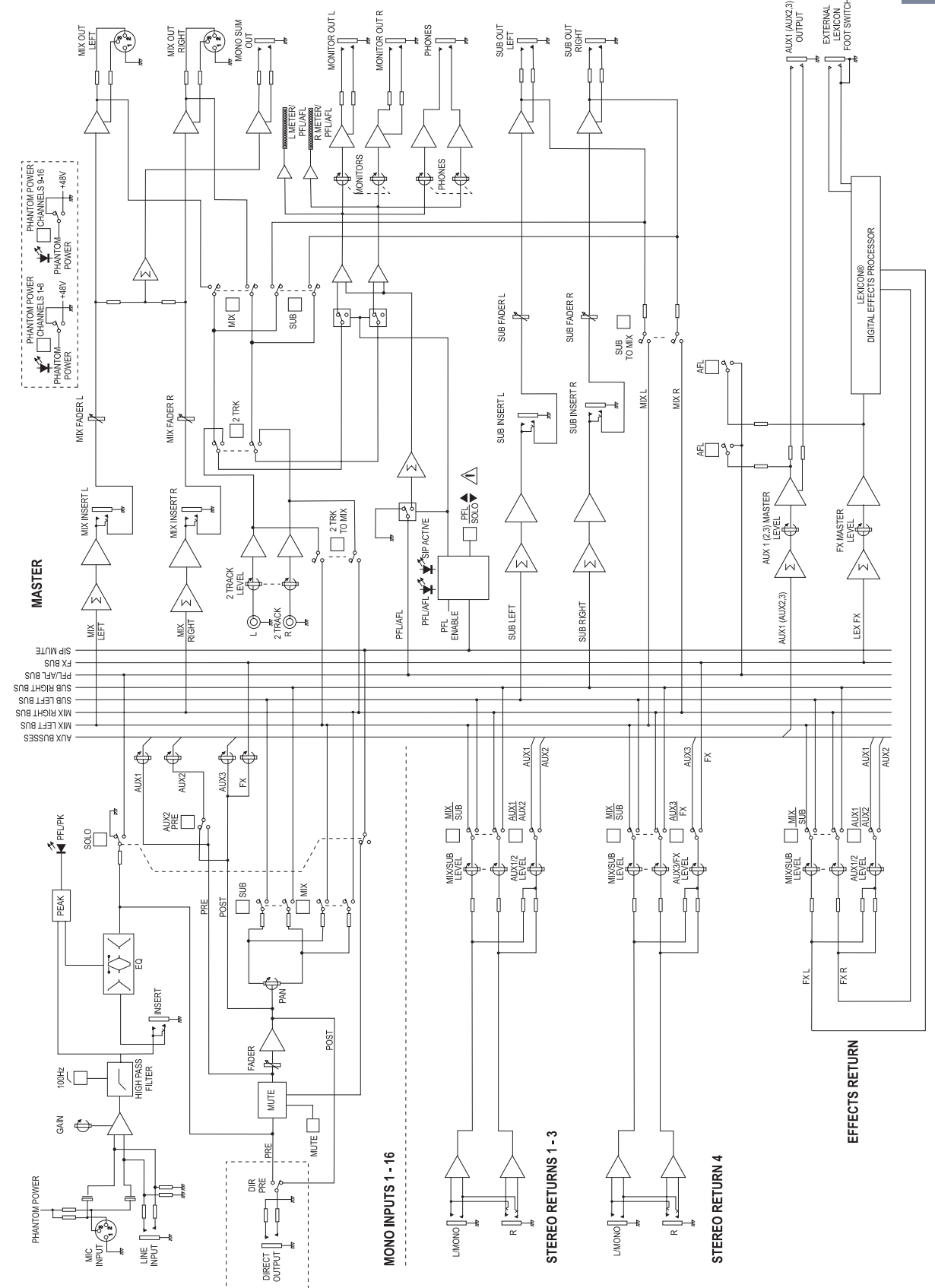

FX16ii
Mono Input Channel

FX16ii
Master Section

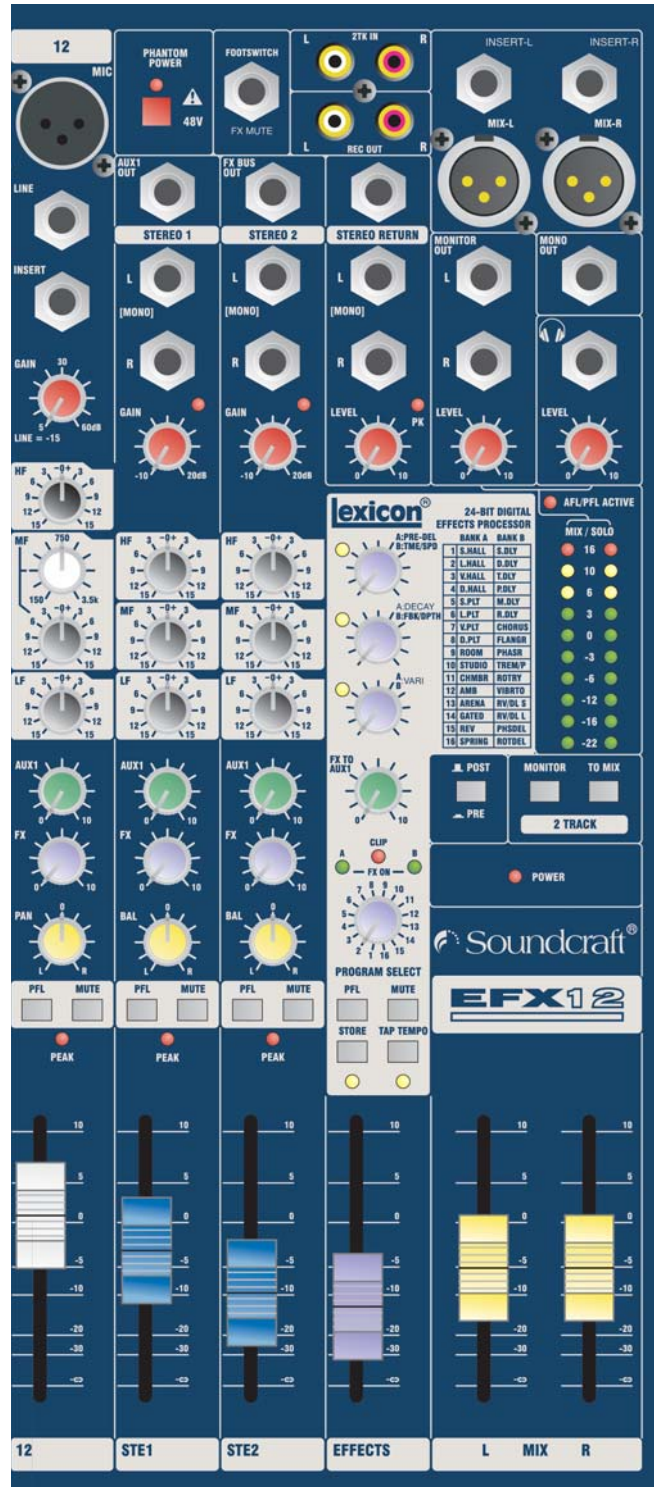

EFX Mono Input Channel EFX Stereo Input Channel EFX Master Section

EFX - EPM: THE DIFFERENCES

EFX input channels feature an FX send to the internal Lexicon effects processor, along with a single Aux send for use with external processors, or to create a monitor mix. With no internal Lexicon effects, EPM input channels replace the FX send with a second Aux send. The EFX stereo input channels feature 3-band EQ. The EPM stereo input channels features 2-band EQ.

MONO INPUT MODULE

Mic Input
A gold-plated balanced female XLR connector accepts balanced or unbalanced mic signals. At -127dBu EIN the mic amp is extremely quiet and transparent with excellent overload characteristics.

Line Input
A balanced 1/4" jack for connecting balanced or unbalanced electronic instruments, such as keyboards.

Insert
Used for patching in compressors or additional EQ or for other signal processors. It can also be used for recording to multi-track recorders if necessary.

Gain
A rotary gain control on each input alters the gain of the input signal, from +5 to +60dB (Line Inputs have -20dB attenuation). Linear circuitry within the preamp delivers smooth gain control over the entire gain range.

EQ Section
Equalisation is split into three bands. The shelving HF control provides 15dB of cut or boost (gain adjustment) for frequencies above 12kHz. A swept mid frequency control enables frequencies from 150Hz to 3.5kHz to be adjusted with up to 15dB of cut or boost at the selected frequency. Signals below 80Hz can be adjusted with the LF control, which features ±15dB of gain adjustment (cut or boost).

Auxiliary Section
One (EFX) or two (EPM) Aux for sending separate monitor mixes in live applications, or for use with external effects. The Aux bus(es) can be globally switched to be pre or post fade on the master section.

FX Send (EFX only)
For sending signal to the internal 24-bit Lexicon effects.

Pan, Muting, and PFL
The Pan control positions each channel's signal across the stereo image, with a Mute button to cut the signal completely. A PFL button solos the signal for monitoring.

Faders and Metering
Each mono channel features a smooth 60mm fader, and a peak level LED indicating signal levels in excess of +17dBu.

STEREO INPUT CHANNEL

Input Connectors
The stereo inputs are connected via balanced 1/4" jack inputs, delivering optimum performance with other professional audio equipment.

EQ Section
The EFX features three fixed shelving controls, adjusting HF signals at 8kHz by ±15db, MF signals at 720Hz by ±15db and LF signals at 60Hz by ±15dB. The EPM features two fixed shelving controls, adjusting HF signals at 12kHz by ±15dBu and LF signals at 80Hz by ±15dB.

Auxiliary Section
The signal(s) can be sent pre-fade or post-fade according to master selection, for use in a monitor mix or for effects processing.

FX Send (EFX only)
For sending signal to the internal 24-bit Lexicon effects.

Bal, Muting, and PFL
The Balance control adjusts the amount of the signal sent to the left and right busses. Mute and PFL buttons operate as on the mono input channels, cutting or soloing the stereo channel. With PFL pressed, the prefade signal is fed to the headphones, control room output and meters.

Faders and Metering
Each stereo channel features a smooth 60mm fader, and a peak level LED indicating signal levels in excess of +17dBu.

MASTER SECTION

Effects (EFX only)
A rotary control selects the effect program, with three rotary controls for effect parameters and one to control the effects level sent to Aux 1. Buttons for PFL, Mute, Store (user effect set-up) and Tap Tempo (for time/speed-based effects such as delays). Footswitch input for FX on/off.

+48V Phantom Power
Global control over professional +48V phantom power is offered via a push button. When active, an LED will illuminate.

2-Track Inputs and Outputs
2-track recorder playback inputs and record sends are on unbalanced RCA phono connectors. Monitor Playback routes the playback input to your monitoring system or to the headphones, replacing any existing monitoring signals. Playback to Mix routes the playback signal directly to the main mix, replacing any signal that may be present, perfect for intermission music or as a master mute.

Monitor Output and Mix Insert
Available on balanced 1/4" jacks.

Stereo Return (EFX only)
Available on 1/4" jacks with level control for use with external processors.

Mix Outputs
The main left and right mix outputs are provided on balanced XLR connectors.

Monitor & Phones Level
Levels sent to the monitor output and headphones can be independently adjusted using these two rotary controls. And when a pair of headphones are plugged into the phones socket at the bottom right of the mixer, the monitor outputs are still operational for simultaneous listening by a performer and engineer.

Faders and Metering
Controlling the overall stereo mix level are two 60mm faders, with two 10-segment 3-colour LED peak-reading bargraph meters monitoring the mix left and right outputs. These meters normally follow the current monitor selection, so if any PFL button is pressed, the meters will switch to monitor this and the PFL Active LED will light.

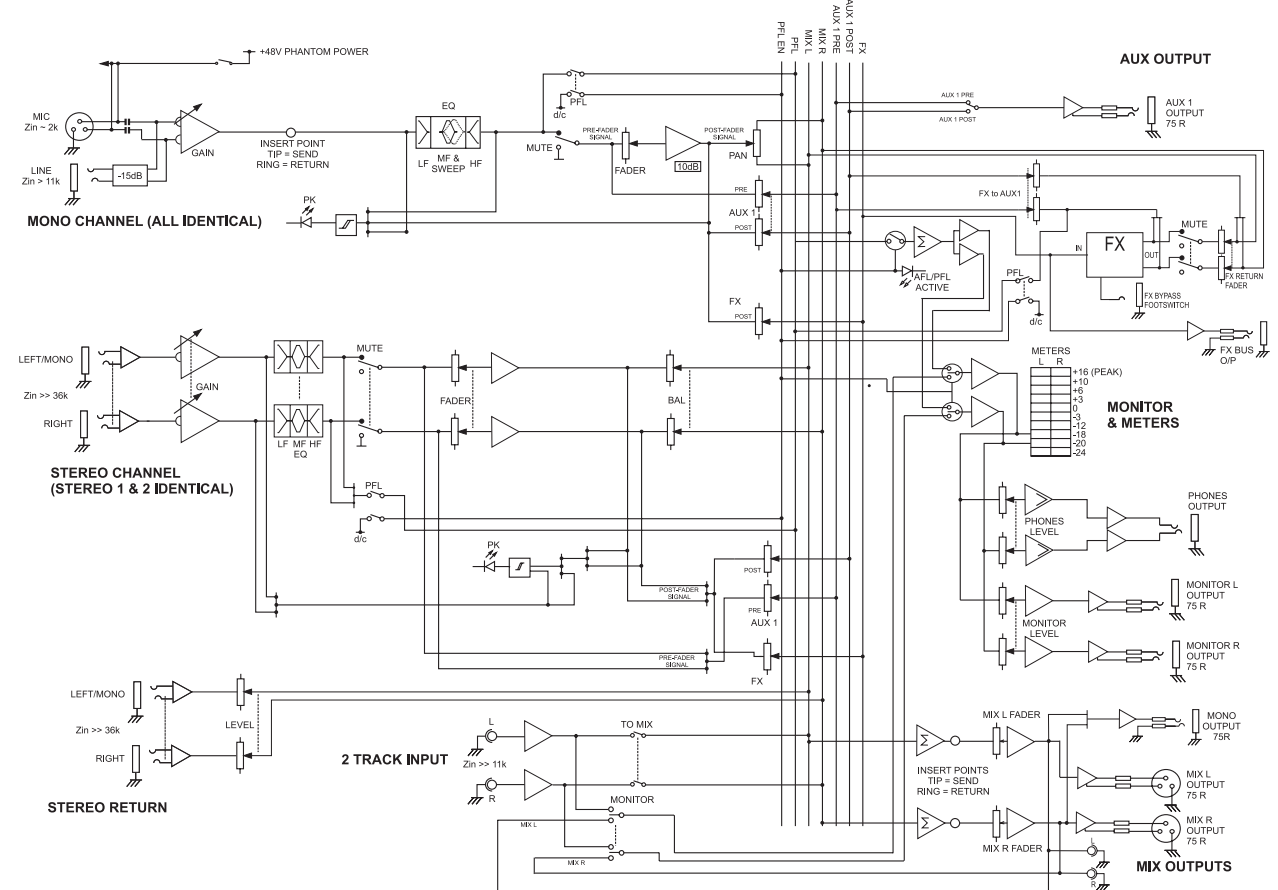
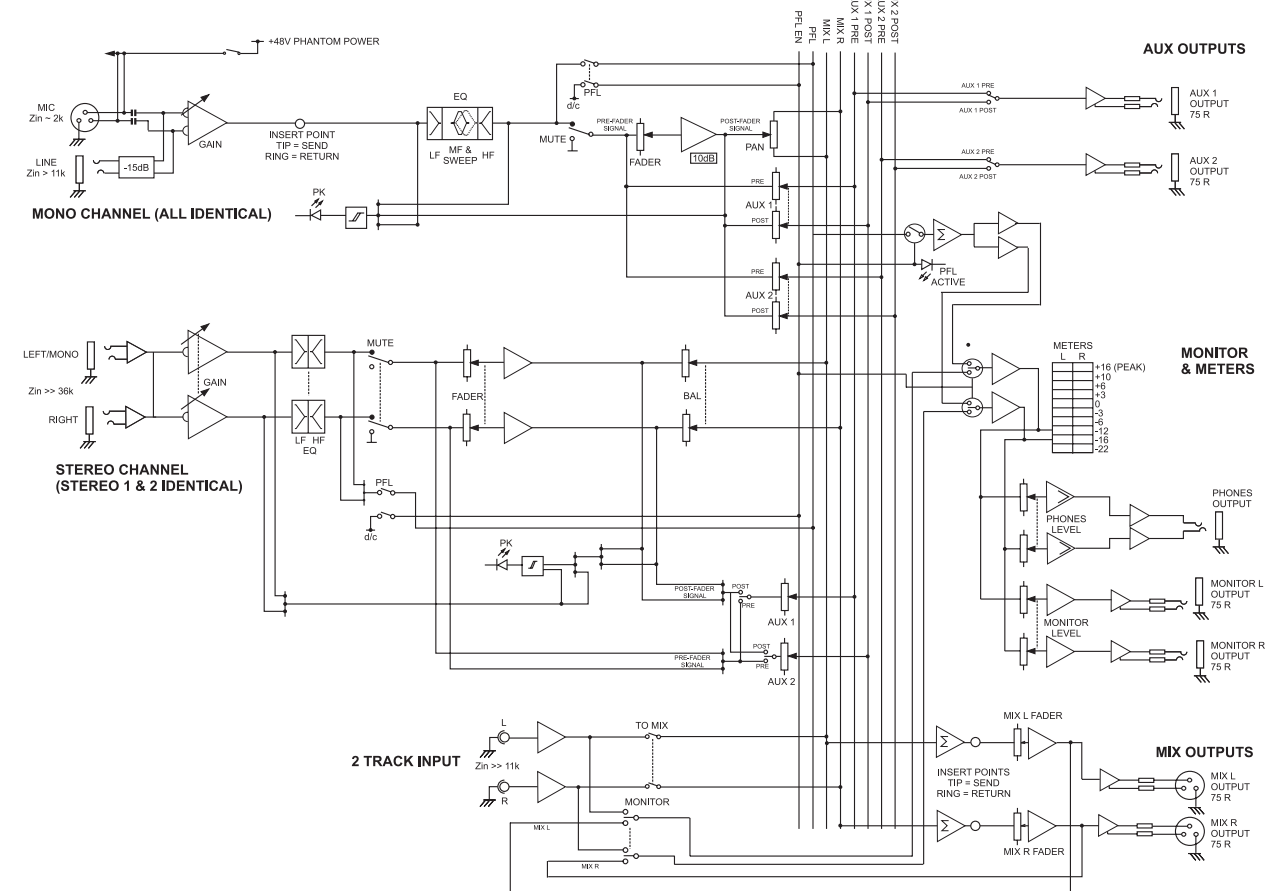

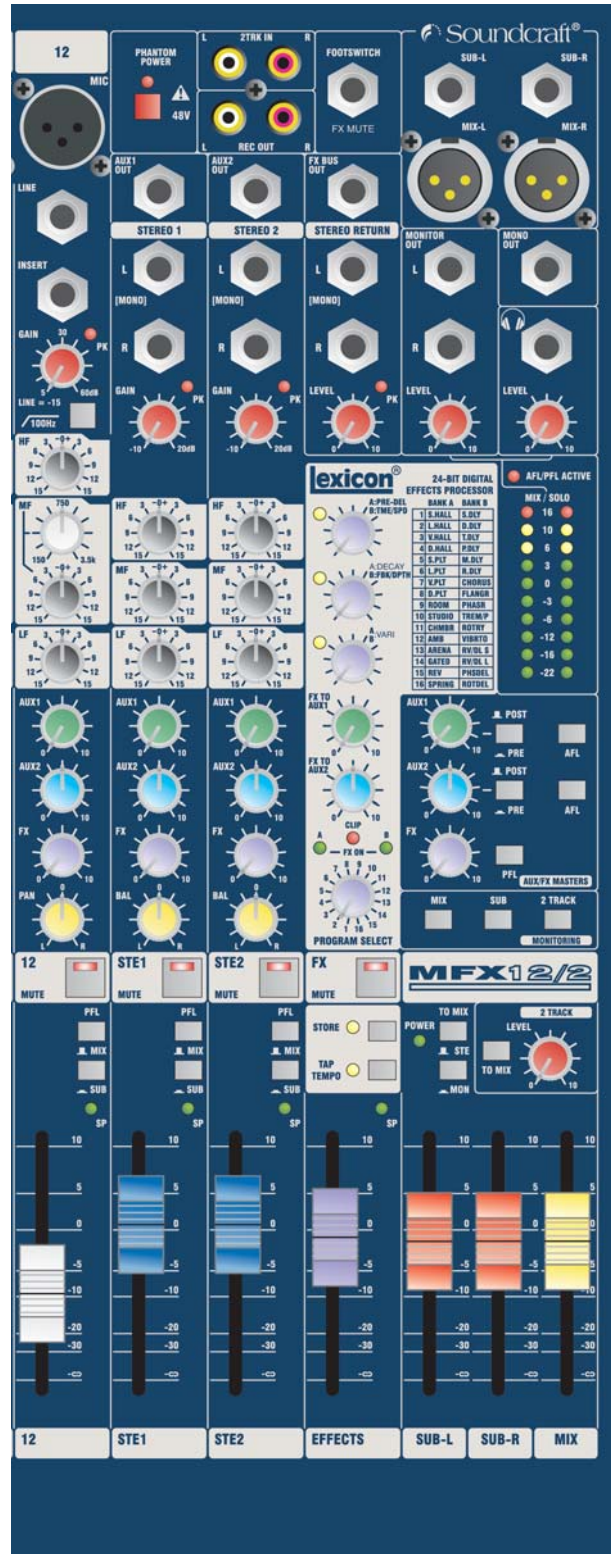

MPM Mono Input Channel MFX Stereo Input Channel MFX Master Section

MFX - MPM: THE DIFFERENCES

MFX input channels feature an FX send to the internal Lexicon effects processor, along with 2 Aux sends for use with external processors, or to create a monitor mix.

With no internal Lexicon effects, MPM input channels replace the FX send with a third Aux send.

MONO INPUT MODULE

Mic Input

A gold-plated balanced female XLR connector accepts balanced or unbalanced mic signals. At -127dbu EIN the mic amp is extremely quiet and transparent with excellent overload characteristics.

Line Input

A balanced 1/4" jack for connecting balanced or unbalanced electronic instruments, such as keyboards.

Insert

Used for patching in compressors or additional EQ or for other signal processors. It can also be used for recording to multi-track recorders if necessary.

Gain

A rotary gain control on each input alters the gain of the input signal, from +5 to +60dB (Line Inputs have -20dB attenuation). Linear circuitry within the preamp delivers smooth gain control over the entire gain range.

EQ Section

Equalisation is split into three bands. The shelving HF control provides 15dB of cut or boost (gain adjustment) for frequencies above 12kHz. A swept mid frequency control enables frequencies from 150Hz to 3.5kHz to be adjusted with up to 15dB of cut or boost at the selected frequency. Signals below 80Hz can be adjusted with the LF control, which features ±15dB of gain adjustment (cut or boost).

Auxiliary Section

Two (MFX) or three (MPM) Aux sends for sending separate monitor mixes in live applications, or for use with external effects. In the Master Section, each Aux bus has its own master level control and AFL switch and can be globally switched pre or post fader (Aux 3 is post fader).

FX Send (MFX only)

For sending signal to the internal 24-bit Lexicon effects.

Pan, Muting, PFL and Routing

The Pan control positions each channel's signal across the stereo image, with an illuminated Mute switch to cut the signal completely. A PFL button solos the signal for monitoring. The mono channels can be routed to either the main Mix outputs or the Sub Groups via the Mix/Grp switch.

Faders and Metering

Each mono channel features a smooth 60mm fader, and a peak level LED indicating signal levels in excess of +17dBu.

STEREO INPUT CHANNEL

Input Connectors

The stereo inputs are connected via balanced 1/4" jack inputs, delivering optimum performance with other professional audio equipment.

EQ Section

There are three fixed shelving controls, adjusting HF signals at 8kHz by ±15dB, MF signals at 720Hz by ±15dB and LF signals at 60Hz by ±15dB.

Auxiliary Section

With 2 (MFX) or 3 (MPM) Aux sends on the stereo input channels, the signal can be sent pre-fade or post-fade according to master selection, for use in a monitor mix or for effects processing.

FX Send (MFX only)

For sending signal to the internal 24-bit Lexicon effects.

Bal, Muting, PFL and Routing

The balance control adjusts the amount of the signal sent to the left and right busses. Mute and PFL buttons operate as on the mono input channels, cutting or soloing the stereo channel. With PFL pressed, the prefade signal is fed to the headphones, control room output and meters. The stereo input channels can be routed to either the main Mix outputs or the Sub Groups via the Mix/Grp switch.

Faders and Metering

Each stereo channel features a smooth 60mm fader, and a peak level LED indicating signal levels in excess of +17dBu.

MASTER SECTION

Effects (MFX only)

A rotary control selects the effect program, with three rotary controls for effect parameters and two to control the effects level sent to Auxes 1 and 2. Buttons for PFL, Mute, Store (user effect set-up) and Tap Tempo (for time/speed-based effects such as delays). Footswitch input for FX on/off.

+48V Phantom Power

Global control over professional +48V phantom power is offered via a push button. When active, an LED will illuminate.

2-Track Inputs and Outputs

2-track recorder playback inputs and record sends are on unbalanced RCA phono connectors. The Playback to Mix control routes the signal directly to the main mix, replacing the signal that is present.

Monitor Switching

Monitor outputs are switchable between 2-track Replay, Mix and Groups.

Monitor Outputs

Available on balanced 1/4" jacks, the Headphone and Control Room monitor outputs feature independent level control.

Mix Outputs

The main left and right mix outputs are provided on balanced XLR connectors.

Stereo Return (MFX only)

Available on 1/4" jacks with level control for use with external processors.

Sub Groups

Control over the Sub Groups comes via L-R Sub Group faders. The Sub Group outputs are 1/4" jacks

Faders and Metering

L-R Group faders control the Sub Group levels while overall stereo mix is handled by a single 60mm fader, with two 10-segment 3-colour LED peak-reading bargraph meters monitoring the mix left and right outputs. These meters normally follow the current monitor selection, so if any PFL button is pressed, the meters will switch to monitor this and the PFL Active LED will light.

MONO CHANNEL (1 - 20 or 1 - 12 ALL IDENTICAL)

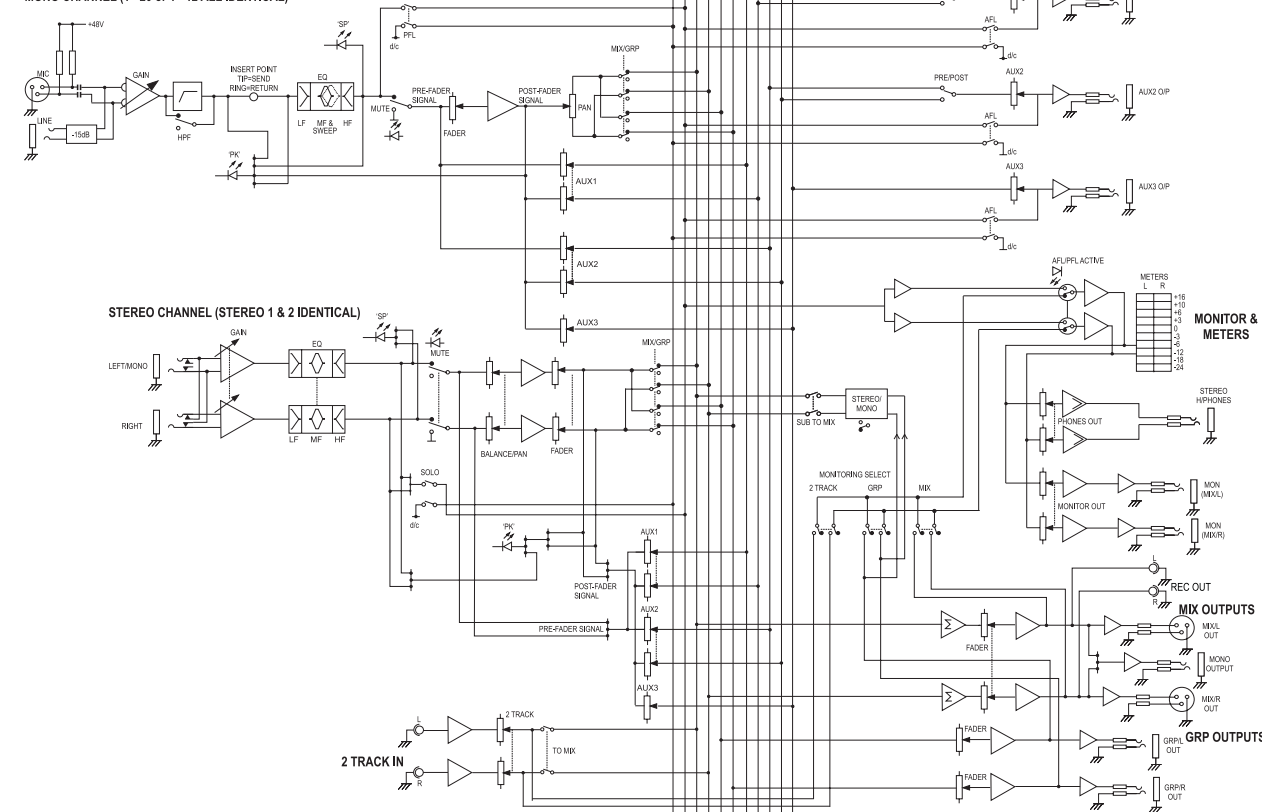

STEREO CHANNEL (STEREO 1 & 2 IDENTICAL)

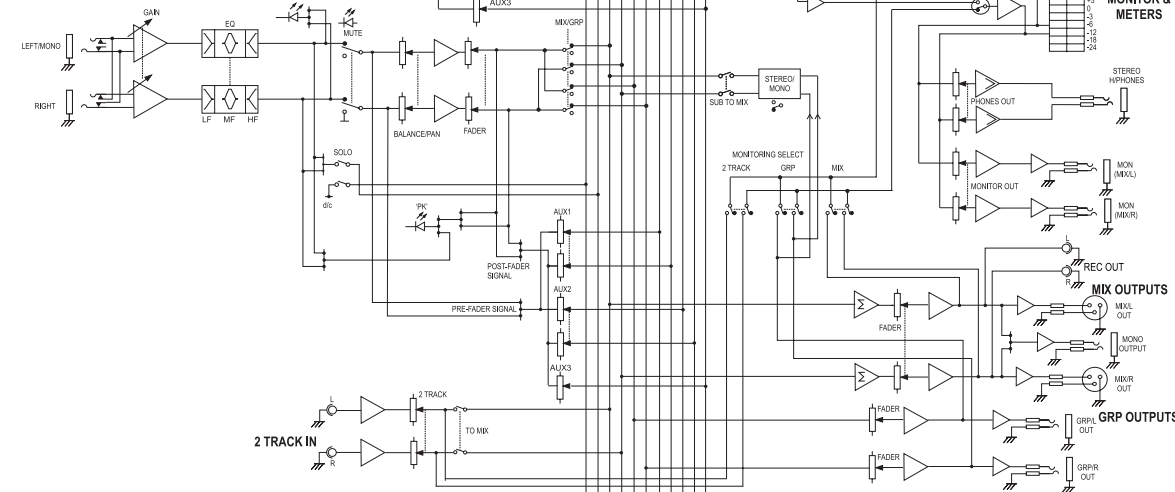

MONO CHANNEL (1 - 20 or 1 - 12 or 1-8 ALL IDENTICAL)

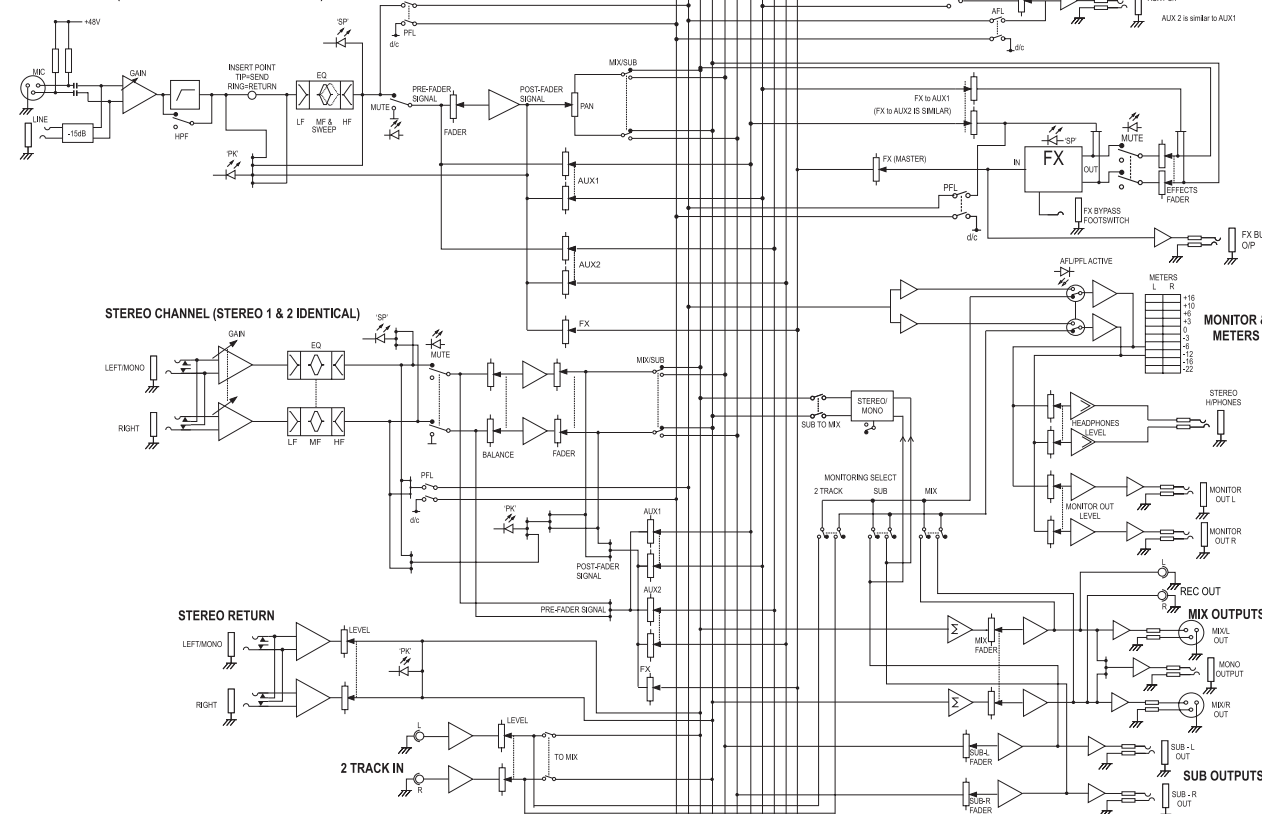

STEREO CHANNEL (STEREO 1 & 2 IDENTICAL)

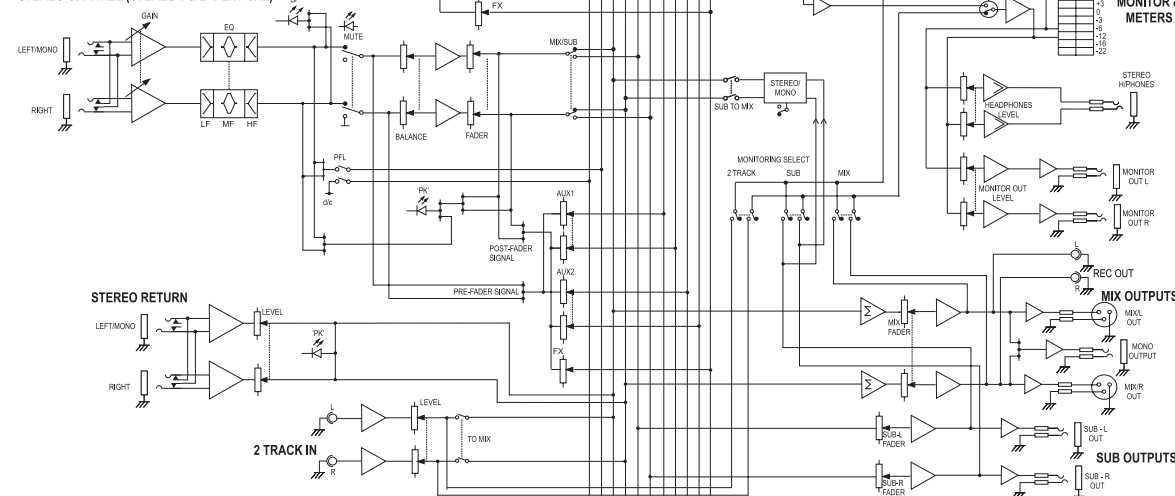

DIMENSIONS & WEIGHTS

SPECIFICATIONS



	Width	Height	Depth	Weight
FX16ii	442mm (17.4")	148mm (5.8")	442mm (17.4")	4.0 kg (8.8 lbs)
FX16ii with rack ears (10U)	481mm (19")	148mm (5.8")	442mm (17.4")	4.0 kg (8.8 lbs)



	Width	Height	Depth	Weight
EPM6	280mm (11.0")	91mm (3.6")	362mm (14.3")	4.0 kg (8.8 lbs)
EPM8	330mm (13.0")	91mm (3.6")	362mm (14.3")	4.6 kg (10.1 lbs)
EPM12	432mm (17.0")	91mm (3.6")	362mm (14.3")	5.8 kg (12.8 lbs)



	Width	Height	Depth	Weight
EFX8	330mm (13.0")	91mm (3.6")	362mm (14.3")	4.6 kg (10.1 lbs)
EFX12	432mm (17.0")	91mm (3.6")	362mm (14.3")	5.8 kg (12.8 lbs)



	Width	Height	Depth	Weight
MPM12/2	432mm (17.0")	94mm (3.7")	405mm (16.0")	6.7 kg (14.8 lbs)
MPM20/2	688mm (27.0")	94mm (3.7")	405mm (16.0")	9.3 kg (20.4 lbs)



	Width	Height	Depth	Weight
MFX8/2	403mm (15.9")	94mm (3.7")	405mm (16.0")	4.0 kg (8.8 lbs)
MFX12/2	482mm (19.0")	94mm (3.7")	405mm (16.0")	6.7 kg (14.8 lbs)
MFX20/2	688mm (27.0")	94mm (3.7")	405mm (16.0")	9.3 kg (20.4 lbs)

FX16ii TYPICAL SPECIFICATIONS

Frequency Response	Mic/Line Input to any Output.....	+/-1dB, 20Hz - 20kHz
T.H.D.	Mic Sensitivity -30dBu, +14dBu @ Mix output.....	< 0.09% @ 1kHz
Noise	Mic Input E.I.N. (maximum gain)..... Aux, Mix and Masters (@ 0dB, faders down).....	-127dBu (150Ω source) < -84dBu
Crosstalk (@ 1kHz)	Channel Mute..... Fader Cut-off (rel +10 mark)..... Aux Send Pots Offness.....	> 96dB > 90dB > 86dB
EQ (Mono inputs)	HF..... MF (swept)..... LF..... Q.....	12kHz, +/-15dB 150Hz - 3.5kHz, +/-15dB 80Hz, +/-15dB 1.5
Power Consumption	Less than 40W
Operating Conditions	Temperature Range.....	5°C to +40°C
Input & Output Levels	Mic Input..... Line Input..... Stereo Input..... Mix Output..... Headphones (@150Ω).....	+15dBu max. +30dBu max. +30dBu max. +20dBu max. 300mW
Input & Output Impedances	Mic Input..... Line Input..... Stereo Input..... Outputs.....	2kΩ 10kΩ 65kΩ (stereo), 35Ω (mono) 150kΩ (balanced), 75Ω (unbalanced)

EPM/EFX TYPICAL SPECIFICATIONS

Frequency Response	Mic/Line Input to any Output.....	+/-1.5dB, 20Hz - 20kHz
T.H.D.	Mic Sensitivity -30dBu, +14dBu @ Mix output.....	< 0.02% @ 1kHz
Noise	Mic Input E.I.N. (maximum gain)..... Aux, Mix and Masters (@ 0dB, faders down).....	-127dBu (150Ω source) < -85dBu
Crosstalk (@ 1kHz)	Channel Mute..... Fader Cut-off (rel +10 mark)..... Aux Send Pots Offness.....	> 96dB > 96dB > 86dB
EQ (Mono inputs)	HF..... MF (swept)..... LF..... Q.....	12kHz, +/-15dB 150Hz - 3.5kHz, +/-15dB 80Hz, +/-15dB 1.5
EQ (Stereo inputs)	HF..... MF (EFX Only)..... LF.....	12kHz, +/-15dB 720Hz, +/-15dB 80Hz, +/-15dB
Power Consumption	Less than 35W
Operating Conditions	Temperature Range.....	5°C to +40°C
Input & Output Levels	Mic Input..... Line Input..... Stereo Input..... Mix Output..... Headphones (@150Ω).....	+15dBu max. +30dBu max. +30dBu max. +20dBu max. 300mW
Input & Output Impedances	Mic Input..... Line Input..... Stereo Input..... Outputs.....	2kΩ 10kΩ 65kΩ (stereo), 35Ω (mono) 150kΩ (balanced), 75Ω (unbalanced)

MPM/MFX TYPICAL SPECIFICATIONS

Frequency Response	Mic/Line Input to any Output.....	+/-1.5dB, 20Hz - 20kHz
T.H.D.	Mic Sensitivity -30dBu, +14dBu @ Mix output.....	< 0.02% @ 1kHz
Noise	Mic Input E.I.N. (maximum gain)..... Aux, Mix and Masters (@ 0dB, faders down).....	-127dBu (150Ω source) < -85dBu
Crosstalk (@ 1kHz)	Channel Mute..... Fader Cut-off (rel +10 mark)..... Aux Send Pots Offness.....	> 96dB > 96dB > 86dB
EQ (Mono inputs)	HF..... MF (swept)..... LF..... Q.....	12kHz, +/-15dB 150Hz - 3.5kHz, +/-15dB 80Hz, +/-15dB 1.5
EQ (Stereo inputs)	HF..... MF..... LF.....	12kHz, +/-15dB 720Hz, +/-15dB 80Hz, +/-15dB
Power Consumption	Less than 40W
Operating Conditions	Temperature Range.....	5°C to +40°C
Input & Output Levels	Mic Input..... Line Input..... Stereo Input..... Mix Output..... Headphones (@150Ω).....	+15dBu max. +30dBu max. +30dBu max. +20dBu max. 300mW
Input & Output Impedances	Mic Input..... Line Input..... Stereo Input..... Outputs.....	2kΩ 10kΩ 65kΩ (stereo), 35Ω (mono) 150kΩ (balanced), 75Ω (unbalanced)

Note: These figures are typical of performance in a normal electromagnetic environment and are often exceeded. Performance may be degraded in severe conditions. All measurements refer to electronically balanced inputs and outputs.



GRAHAM BLYTH FRSA

To mark Soundcraft's 30th anniversary, co-founder and Technical Director, Graham Blyth, took a well established and classic Soundcraft microphone preamplifier to a new level of performance, resulting in the new GB30 preamp which boasts extraordinary clarity with exceptionally controlled overload characteristics.



Soundcraft Registered Community Trade Mark/RTM No. 000557827

SOUNDCRAFT

HARMAN INTERNATIONAL INDUSTRIES LTD.,
CRANBORNE HOUSE, CRANBORNE ROAD
POTTERS BAR, HERTS, EN6 3JN, UK
T: +44 (0)1707 665000
F: +44 (0)1707 660742
E: info@soundcraft.com

SOUNDCRAFT USA

8500 BALBOA BLVD.
NORTHRIDGE, CA 91329, USA
T: +1-818-920-3212
F: +1-818-920-3208
E: soundcraft-usa@harman.com

www.soundcraft.com

Soundcraft reserves the right to improve or otherwise alter any information supplied in this document or any other documentation supplied hereafter. E&OE 05/07

This equipment complies with the EMC Directive 89/336/EEC

Part No: ZL0605



H A Harman International Company